

# FLOW SWITCHES FF81 FOR PIPES FROM G1 TO G4 FF84 FOR PIPES FROM G1 TO G10

**FF81**  
**FF84**

## GENERAL CHARACTERISTICS

Flow switches are suitable to control and adjust air in conditioning. It acts in compliance with the technical regulations of the M.D. 1/12/1975 (Safety standards for the instruments containing hot liquids under pressure) and with the collection R file R.2.C.6. Into heating plants with closed expansion tank where the circulation is guaranteed by electropumps, the heat supply must be automatically interrupted in case of stop of the circulation pumps.

## FUNCTIONING AND INSTALLATION

A flexible paddle works on a lever starting a microswitch in SPDT. The electrical connection can be prearranged to control pumps, burners, compressors, motoroperated valve, signalling alarms. It is installed on sections of horizontal pipe, far from valves, elbows, irregular flows or discharges. The straight pipe must be at least 5 times of the long of the of the pipe. The flow direction must follow the arrow designed on the instrument. Check the correct installation and the correct functioning, pretending the flow inside the pipe manually pushing the lever untill you close the C-NO contact. Then check the opening of the contact.

## MOUNTING EXEMPLE

ON PIPELINES G1

ON PIPELINES FROM G2 TO G10

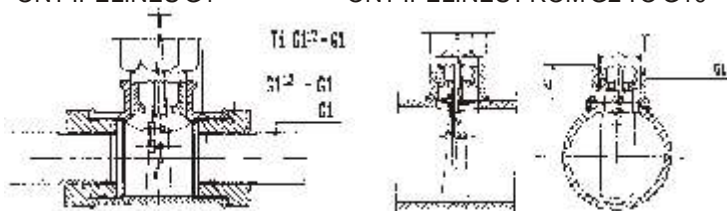

## TECHNICAL CHARACTERISTICS

**FF81** has shock-resistant enclosure, protection degree IP54, sealed-gland in nylon G 3/8, lever group from G1 to G4 (the G1 and G2 levers are already mounted).

**FF84** had a inox enclosure, protection degree IP54, sealed-gland in nickel-plated brass G 3/8, lever group from G1 to G10 already mounted).

## TECHNICAL CHARACTERISTICS OF BOTH MODELS

Brass threaded connection from G1  
Lever group for pipelines in inox  
AISI 316

Unipolar microswitch in SPDT  
changeover with ASE-UL-CSA-BS-  
VDE standards.

Electrical connections on 6.3  
Faston (on issue)

Calibration screw for the regulation  
of the intervention point.

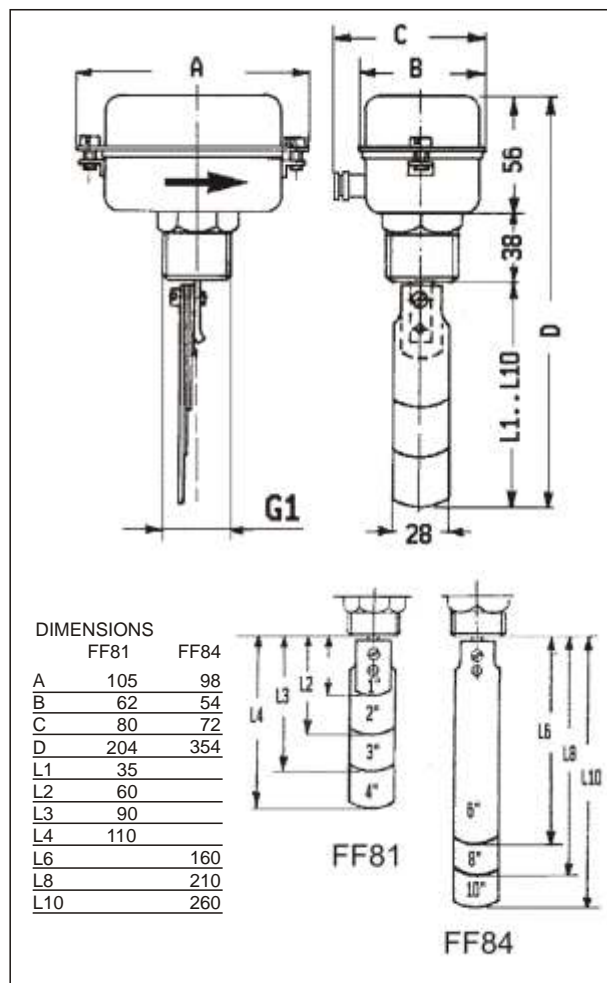
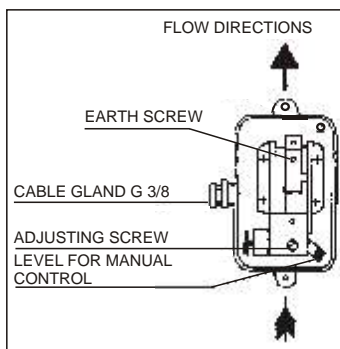

## TECHNICAL FEATURE

Max. working pressure 10 bars  
Max. temperature of the controlled fluid 50°C  
Working temperature -20 to 110°C  
SPDT microswitch according to  
ASE-UL-CSA-BS-VDE.  
According standards CEI EN 60947-5-1

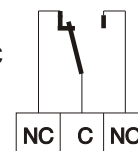

Nominal insulation tension U<sub>i</sub> 380V~  
Continuous duty nominal current I<sub>th</sub> 10A  
Operating nominal current I<sub>e</sub>:

		230V - 250V~
Resistive load	AC-12	- 10A
Inductive load	AC-15	- 3A
Direct current	DC-13	0,2A -

TYPE	PIPELINE DIAMETER	LEVER	Minimum Calibration Value dm <sup>3</sup> /sec		Maximum Calibration Value dm <sup>3</sup> /sec	
			Increasing flow	Decreasing flow	Increasing flow	Decreasing flow
<b>FF81</b>	G1	L1	0.26	0.16	0.58	0.53
	G2	L2	0.8	0.6	0.7	1.6
	G3	L3	1.7	1.2	3.2	3
	G4	L4	2.2	1.7	5.1	4.8
<b>FF84</b>	G6	L6	4.7	3.4	9	8.5
	G8	L8	12.9	12.7	26	25.2
	G10	L10	22	22	46.5	41